



Self-contained ice maker - Granular system
Daily production up to 125 kg

Hotel	██████████
Restaurant	██████████
Fast food	██████████
Bar	██████████
Disco	██████████
Fish market	██████████
Supermarket	██████████
Medical & SPA	██████████
Industry	██████████

► Position n°



► Features & Plus

- Granular ice - 80-82% dry
- 1l (water) - 1kg (ice) - only Air cooled
- AISI 304 SS Scotch Brite finish
- Tropical class +43°C
- Adjustable Stainless Steel feet
- Removable and cleanable air filter
- AISI 304 SS evaporator
- Air or water cooling system
- Easy cleanable internal rounded surfaces
- HCFC-Free insulated storage
- Dust-proof water basin
- RoHS Free
- Disappearing insulated door
- Electromechanical operation
- ON-OFF rocker switch
- Automatic water charge
- Standard and special voltages
- HFC Free



AISI 304 SS Scotch Brite finish



Removable and cleanable air filter



AISI 304 SS evaporator



Dust-proof water basin



Disappearing insulated door

► Prod. 24h

🌡️	Air temp.		Water temp.		Kg	Lbs
	10° C	50° F	7° C	45° F		
	21° C	70° F	15° C	60° F		
					125	276
					113	249

► Certifications available for this model



www.bremaice.it
info@bremaice.it

We are Brema





Ice Flakes

FHT90 A/W HC

Self-contained ice maker - Granular system
Daily production up to 125 kg

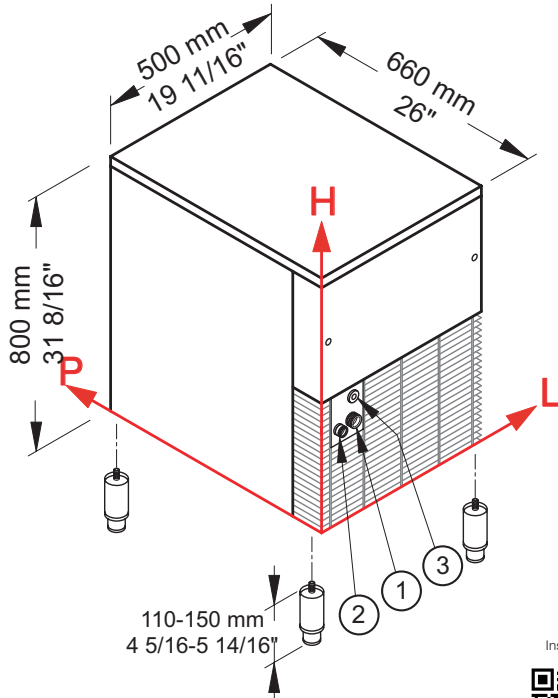

Installation

**► Working conditions**

- Location: **Indoor**

	Min	Max
Ambient temperature	+10° C / +50° F	+43° C / 110° F
Water temperature	+3° C / +37° F	+32° C / +90° F
Voltage	-10%	+10%
Water inlet pressure	1bar (14 psi)	6bar (84 psi)

► Performances

Air temperature	Water temperature	Water temperature					
		7° C	45° F	15° C	60° F	21° C	70° F
10° C	125 kg						
50° F	276 lbs						
21° C			113 kg				
70° F				249 lbs			
32° C					93 kg		
90° F						205 lbs	

► Connections

All measures are referred to the rear bottom-left corner (L-H-Ø)

- ① Water in.: 99 mm / 3 14/16" - 158 mm / 6 4/16" - 3/4" ② Water out.: 48 mm / 1 14/16" - 151 mm / 5 15/16" - 24 mm / 15/16"
 ③ Electrical connections: 87 mm / 3 7/16" - 230 mm / 9 1/16"

► Technical information

Production in 24h	113 kg / 249 lbs	Water consumption	A: 1 l/kg - 12,0 gal/100 lbs
Store capacity, up to	30 kg / 66 lbs		W: 7 l/kg - 84 gal/100 lbs
Cooling system	A - W	Sizes (L-P-H mm)	500 - 660 - 800
Refrigerant	R290	(L-P-H in)	19 11/16 - 26 - 31 8/16
Standard voltage	220-240 V ~ 50 Hz	Sizes with pack (L-P-H mm)	550 - 720 - 990
Average power consumption	470 W	(L-P-H in)	21 10/16 - 28 6/16 - 39
Fuse	10 A	Net weight	67 kg / 148 lbs
Electrical consumption	11 kWh/100kg	Gross weight	76 kg / 168 lbs
Finish	AISI 304 stainless steel, scotch brite		

All the technical information must be considered at the following conditions:

- Sizes without feet
- Ambient temperature +21° C
- Water temperature +15° C
- Electrical consumption at +32° C (standard voltage)
- Average power consumption at +43° C (standard voltage)

Models and specifications are subject to change without notice

Rev. 04 - Issued September 2019

Bim + Data download

